

SPECIALTY CASTERS

CAPACITY RANGE 210-1500 LBS



DC Dolly Casters

An Economical and Floor Protective Dolly Solution

Common Applications:

- Business Machines
- Server Racks
- Cabinets/Cases
- Vending Machines
- Industrial Carts
- Material Handling Equipment
- Economical Carts
- Swing or Sliding Gates



20/21 Series Business Machine
Capacity to 1200 123



E-Line
Medium Heavy Duty Economical
Capacity to 1250 126-128



DC Dolly Casters
Capacity to 350 124



Gate Casters
Capacity to 210 129



Bassick Honcho AS Series
Capacity to 1250 125

Custom Fabrication (see pages 16-17)

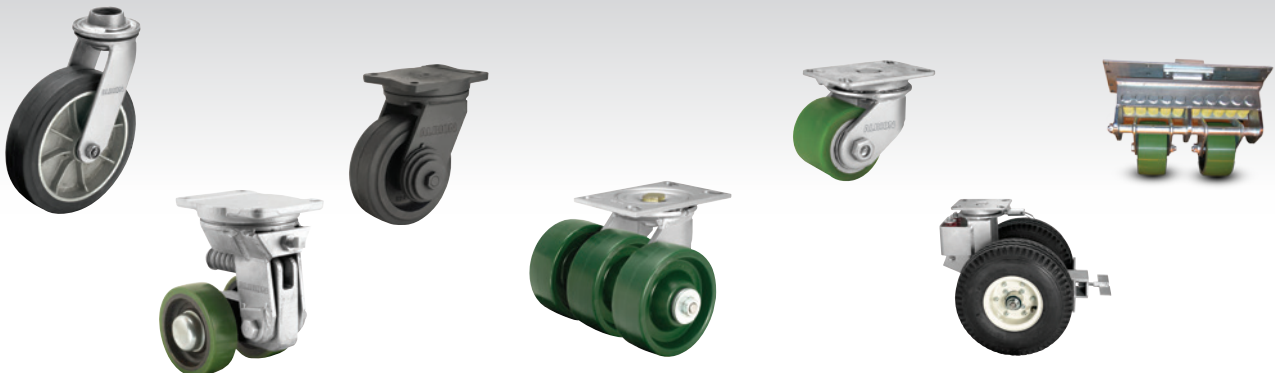

20 21

Business Machine Low Profile Casters CAPACITY TO 1200



MOUNTING OPTIONS

Standard Model Plate

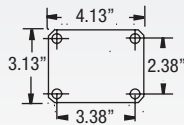

Attaching Bolt
20 Series: 5/16"
21 Series: 3/8"

O2 Series Model Plate

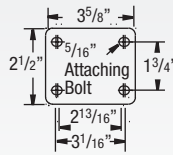

Specify O2 at end of caster part no.

TYPICAL APPLICATIONS

- Dollies
- Server shelves
- Cabinets/Cases
- Soda machines
- Vending Equipment
- Business machine equipment



Premium Quality



Environmentally Friendly

FEATURES

- **Construction:** 20 Series: Heat treated stamped steel. 21 Series: welded steel
- **Finish:** Black finish for corrosion prevention and sleek appearance

RIG OPTIONS

- **Zinc finish option** specify **ZN**



- **4.03" overall height option**, consult factory
- **Optional mounting hole diameters** available, consult factory

BEARING OPTIONS



Straight Roller (O1) Drawn Cup Roller (O2) Precision Ball (28)

BRAKE OPTIONS

Thumbscrew specify **B**



- High Capacity
- Low Height
- Stamped or Welded Construction

+ For swivel models add "S", for rigid model add "R" to end of base caster number.

Wheel Diameter (Inches)	Tread Width (Inches)	Capacity (Lbs) (Rated for manual operation)	Overall Height (Inches)	Swivel Lead (Inches)	Approx. Wt. (Lbs)	Base Caster Number+
-------------------------	----------------------	---	-------------------------	----------------------	-------------------	---------------------

20 Series Business Machine

	Polypropylene (Roller Bearing)	3	1.81	500	3.97	1.08	3	20PB03201
	Nylon Glass Filled (Roller Bearing)	3	1.81	700	3.97	1.08	3	20NG03201
	Phenolic (Roller Bearing)	3	1.81	700	3.97	1.08	3	20TM03201
	Solid Polyurethane (Precision Ball Bearing)	3	1.81	700	3.97	1.08	3	20XP03228

Axle diameter is 7/16"

+ For swivel models add "S", for rigid model add "R" to end of base caster number.

Wheel Diameter (Inches)	Tread Width (Inches)	Capacity (Lbs) (Rated for manual operation)	Overall Height (Inches)	Swivel Lead (Inches)	Approx. Wt. (Lbs)	Base Caster Number+
-------------------------	----------------------	---	-------------------------	----------------------	-------------------	---------------------

21 Series Business Machine

	Nylon Glass Filled (Roller Bearing)	3	1.81	1200	4.16	.81	3	21NG03201
	Phenolic (Roller Bearing)	3	1.81	1000	4.16	.81	3	21TM03201
	Solid Polyurethane (Sealed Precision Ball Bearing)	3	1.81	1200	4.16	.81	3	21XP03228

Axle diameter is 1/2"

Note: Lead times may vary on certain items, consult factory.

DC

DC Dolly Casters

CAPACITY TO 350



FEATURES

- **Swivel Section:** Double ball raceway for standard top plate (Single ball raceway for optional S01 top plate)
- **Finish:** Zinc plated finish
- **Thread Guards:** Interlocking thread guards standard on XS models, keeping out entangling debris for longer life
- **Construction:** Riveted construction
- Alternate or custom caster configurations available

RIG OPTIONS

NSF: Consult factory

BRAKE OPTION

Face Contact specify F



BEARING OPTIONS

Annular Ball (31)
Plain (41)

An ideal solution for dolly applications; the DC Dolly lineup is both economical and durable. All wheels are non-marking, and the XS wheels feature interlocking thread guards to protect them from entangling debris.

TYPICAL APPLICATIONS

- Dolly carts
- Display carts

SWIVEL CROSS SECTION

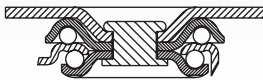

MOUNTING OPTIONS Standard Plate

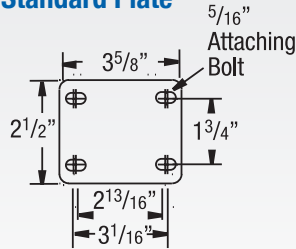

Special Order Plates S01 Top Plate for parts ending in S01

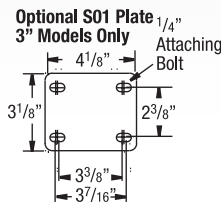

- Economical
- Non marking
- Thread guards protect axle from entangling debris

+ For swivel models add "S", for rigid model add "R" to end of base caster number.

	Wheel Diameter (Inches)	Tread Width (Inches)	Capacity (Lbs) (Based for manual operation)	Overall Height (Inches)	Swivel Lead (Inches)	Approx. Wt. (Lbs)	Base Caster Number+
TPR Rubber (31 Annular Ball Bearing)							
XS	3	1 1/4	275	3.8	1 1/4	.5	DCXS03031S01
	3	1 1/4	275	4 1/4	1 11/16	.5	DCXS03031
	3 1/2	1 1/4	300	4 3/4	1 11/16	.5	DCXS03X31
	4	1 1/4	325	5 1/4	1 11/16	.5	DCXS04031
	5	1 1/4	350	6 1/4	1 11/16	.5	DCXS05031

Non-marking TPR wheel (75 Shore A)

Polyurethane on Polypropylene (41 Plain Bearing)

	Wheel Diameter (Inches)	Tread Width (Inches)	Capacity (Lbs)	Overall Height (Inches)	Swivel Lead (Inches)	Approx. Wt. (Lbs)	Base Caster Number+
XA	3	1 1/4	275	3.8	1 1/4	.5	DCXA03041S01
	3	1 1/4	275	4 1/4	1 11/16	.5	DCXA03041
	3 1/2	1 1/4	300	4 3/4	1 11/16	.5	DCXA03X41
	4	1 1/4	325	5 1/4	1 11/16	.5	DCXA04041
	5	1 1/4	350	6 1/4	1 11/16	.5	DCXA05041

+ For swivel models add "S", for rigid model add "R" to end of base caster number.

	Wheel Diameter (Inches)	Tread Width (Inches)	Capacity (Lbs) (Based for manual operation)	Overall Height (Inches)	Swivel Lead (Inches)	Approx. Wt. (Lbs)	Base Caster Number+
Polypropylene (41 Plain Bearing)							
PB	3	1 1/4	275	3.8	1 1/4	.5	DCPB03041S01
	3	1 1/4	275	4 1/4	1 11/16	.5	DCPB03041
	3 1/2	1 1/4	300	4 3/4	1 11/16	.5	DCPB03X41
	4	1 1/4	325	5 1/4	1 11/16	.5	DCPB04041
	5	1 1/4	350	6 1/4	1 11/16	.5	DCPB05041

AS Bassick Honcho



Legendary Bassick Honcho casters feature sealed upper and lower raceways for additional protection from the elements. The caster legs are embossed, formed legs for added strength. Yellow dichromate finish for added corrosion resistance.

MOUNTING OPTION

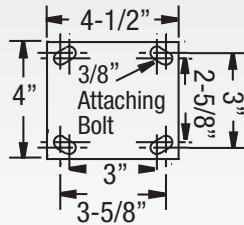

TYPICAL APPLICATIONS

- Platform trucks
- Warehouse trucks
- Material handling containers
- Floor trucks

For rigid models change "CAS" to "CAR"

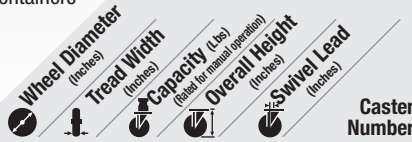

Soft Rubber (51 Roller Bearing)						
SFR	5	2	450	6 1/2	3 11/16	CAS50156YZ-SFR51(KK)
	6	2	475	7 1/2	4 3/8	CAS60156YZ-SFR51(KK)
	8	2	600	9 1/2	5 13/16	CAS80156YZ-SFR51(KK)

Hard Rubber (51 Roller Bearing)						
HDR	5	2	600	6 1/2	3 11/16	CAS50156YZ-HDR51(KK)
	6	2	650	7 1/2	4 3/8	CAS60156YZ-HDR51(KK)
	8	2	750	9 1/2	5 13/16	CAS80156YZ-HDR51(KK)

Polyolefin (51 Roller Bearing)						
POD	4	2	600	5 1/2	3	CAS40156YZ-POD51(KK)
	5	2	650	6 1/2	3 11/16	CAS50156YZ-POD51(KK)
	6	2	700	7 1/2	4 3/8	CAS60156YZ-POD51(KK)
	8	2	900	9 1/2	5 13/16	CAS80156YZ-POD51(KK)

Phenolic (51 Roller Bearing)						
PHN	4	2	800	5 1/2	3	CAS40156YZ-PHN51(KK)
	5	2	1250	6 1/2	3 11/16	CAS50156YZ-PHN51(KK)
	6	2	1200	7 1/2	4 3/8	CAS60156YZ-PHN51(KK)
	8	2	1250	9 1/2	5 13/16	CAS60156YZ-PHN51(KK)

FEATURES

- **Upper/Lower Raceway Rubber seals:** Rubber swivel raceway seals help protect casters
- **Finish:** Attractive yellow dichromate finish for added corrosion resistance
- **Top Plate & Yoke Base:** Cold formed
- **Swivel Section:** Full double ball heat treated raceways. Drawn and formed ballcup
- **Fork Legs:** Embossed, formed legs for added strength
- Alternate or custom caster configurations available

BRAKE OPTIONS

Add brake code to end of caster number

Total Lock
specify -TLB



Side Lock
specify -SB

Swivel Lock
specify -SL



BEARING OPTIONS

Straight Roller (51) Sealed Roller (81)



For rigid models change "CAS" to "CAR"

K Solid Urethane (81 Sealed Roller Bearing)						
KPU	4	2	700	5 1/2	3	CAS40156YZ-KPU81(KK)
	5	2	1000	6 1/2	3 11/16	CAS50156YZ-KPU81(KK)
	6	2	1200	7 1/2	4 3/8	CAS60156YZ-KPU81(KK)
	8	2	1250	9 1/2	5 13/16	CAS80156YZ-KPU81(KK)

RT Reinforced Thermoplastic (51 Roller Bearing)						
FRT	4	2	700	5 1/2	3	CAS40156YZ-FRT51(KK)
	5	2	1000	6 1/2	3 11/16	CAS50156YZ-FRT51(KK)
	6	2	1200	7 1/2	4 3/8	CAS60156YZ-FRT51(KK)
	8	2	1250	9 1/2	5 13/16	CAS80156YZ-FRT51(KK)

Eagle Urethane (51 Roller Bearing)						
EAG	4	2	600	5 1/2	3	CAS40156YZ-EAG51(BK)
	5	2	1100	6 1/2	3 11/16	CAS50156YZ-EAG51(BK)
	6	2	1100	7 1/2	4 3/8	CAS60156YZ-EAG51(BK)
	8	2	1250	9 1/2	5 13/16	CAS80156YZ-EAG51(BK)

Urethane on Aluminum (81 Sealed Roller Bearing)						
UOA	5	2	1250	6 1/2	3 11/16	CAS50156YZ-UOA81(BG)
	6	2	1250	7 1/2	4 3/8	CAS60156YZ-UOA81(BG)
	8	2	1250	9 1/2	5 13/16	CAS80156YZ-UOA81(BG)

Steel (51 Roller Bearing)						
STL	4	2	1200	5 1/2	3	CAS40156YZ-STL51(GG)
	5	2	1250	6 1/2	3 11/16	CAS50156YZ-STL51(GG)
	6	2	1250	7 1/2	4 3/8	CAS60156YZ-STL51(GG)
	8	2	1250	9 1/2	5 13/16	CAS80156YZ-STL51(GG)

E-Line Economical Casters

CAPACITY TO 1250



The E-line is an economical lineup of casters and wheels designed and mass-produced for a range of medium duty applications with load requirements ranging from 300 to 1,250 lbs. per caster. From shop carts and containers, to platform and lumber carts – the E-Line is your most competitive and in-stock 2" wide solution.

TYPICAL APPLICATIONS

- Shop Carts
- Retail Platform and Lumber Carts
- Warehouse Carts and Trucks
- Waste Containers
- Dollies
- Toolboxes

SWIVEL CROSS SECTION

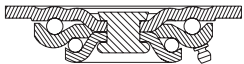

MOUNTING OPTION

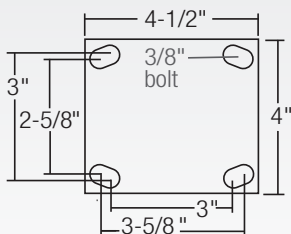

FEATURES

- **Top Plate & Yoke Base:** Cold formed from 1/4" steel plate. Yoke base is notched for factory or field-installable 4-position swivel lock
- **Swivel Section:** Double ball raceways for smooth swiveling action
- **Fork Legs:** 1/4" thick steel leg construction on swivel and rigid casters ... 3/16" construction on total lock casters
- **Kingpin:** 5/8" diameter permanent rivet kingpin
- **Axle:** 1/2" hollow axle with grease zerk and lock nut
- **Wheel seals:** Nylon seal retaining/thrust washers
- **RoHS:** RoHS compliant industrial zinc finish for corrosion resistance
- **Lubrication:** Zerk fitting in swivel section and in recessed head of hollow axle on straight roller and Delrin bearing wheels
- **NSF:** Select models (consult factory)
- **Thread Guards:** Select models have thread guard option (consult factory)

BEARING OPTIONS

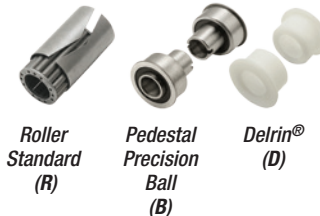

Roller Standard (R)

Pedestal Precision Ball (B)

Delrin® (D)

To change the standard roller bearing to an optional bearing in a caster, add **B** or **D** to the end of caster number.

Plastic retainer washers come standard on wheels with roller bearings; to order optional steel retainer washers add **SW** to the end of the part#. Example ES6X2CIRSW

RIG OPTIONS

- Sealed raceway option. Add **RS** after ES for free swivel models (example: ESRS6X2TPR). Seals are not available for total lock models.
- Integrated total lock brake, see brake options below. Maximum weight capacity of total lock brake models is 900lbs.

BRAKE OPTIONS

To order, add brake code below to end of model. Example: ES6X2MORWFB

Total Lock change ES to ET in charts on right.



Wheel Face All swivel models along with 6" and 8" rigid models specify **WFB**

Tread Brake swivel and rigid models specify **TBK**



Short Pedal -5" length cam swivel and rigid models. Roller bearing required specify **CAMS**

Long Pedal -7" length cam swivel and rigid models. Roller bearing required. Not available on 4" diameter models, specify **CAML**



Hand operated field installable swivel lock order **SWVLOCKX2** separately

E-Line Examples

ES6X2MOR



ES6X2TPDWFB



ES6X2TUMCAMS



ER6X2PDTBK



ES6X2MOPTBK



ET6X2TPR



ER6X2TPUCAML



ET6X2PKTP8



ES6X2PHNCAML



ES6X2CIR



+ Swivel models shown in chart, for rigid models change 1st two digits "ES" to "ER".

Wheel Diameter (Inches)	Tread Width (Inches)	Capacity (Lbs) (Based on manual operation)	Overall Height (Inches)	Swivel Lead (Inches)	Approx. Wt. (Lbs)	Caster Number+

Moldon Rubber (R Roller Bearing)

MOR	4	2	400	5 ⁵ / ₈	3 ³ / ₈	—	ES4X2MOR
	5	2	400	6 ¹ / ₂	4	—	ES5X2MOR
	6	2	550	7 ¹ / ₂	4 ³ / ₄	—	ES6X2MOR
	8	2	600	9 ¹ / ₂	6 ¹ / ₄	—	ES8X2MOR

To change the standard roller bearing to an optional bearing, add **B** (Precision Ball) to the end of the part #.

Thermo-Rubber (Donut) (R Roller Bearing)

TPD	4	2	300	5 ⁵ / ₈	3 ³ / ₈	—	ES4X2TPD
	5	2	350	6 ¹ / ₂	4	—	ES5X2TPD
	6	2	500	7 ¹ / ₂	4 ³ / ₄	—	ES6X2TPD
	8	2	600	9 ¹ / ₂	6 ¹ / ₄	—	ES8X2TPD

To change the standard roller bearing to an optional bearing, add **B** (Precision Ball) or **D** (Delrin) to the end of the part #.

PolyKat™ Thermo-Urethane (TP8 Precision Ball Bearing)

PKTP8	4	2	600	5 ⁵ / ₈	3 ³ / ₈	—	ES4X2PKTP8
	5	2	800	6 ¹ / ₂	4	—	ES4X2PKTP8
	6	2	1000	7 ¹ / ₂	4 ³ / ₄	—	ES4X2PKTP8
	8	2	1200	9 ¹ / ₂	6 ¹ / ₄	—	ES8X2PKTP8

Thermo-Urethane (Maroon/Grey) (R Roller Bearing)

TUM	4	2	500	5 ⁵ / ₈	3 ³ / ₈	—	ES4X2TUM
	5	2	600	6 ¹ / ₂	4	—	ES5X2TUM
	6	2	720	7 ¹ / ₂	4 ³ / ₄	—	ES6X2TUM
	8	2	800	9 ¹ / ₂	6 ¹ / ₄	—	ES8X2TUM

To change the standard roller bearing to an optional bearing, add **B** (Precision Ball) or **D** (Delrin) to the end of the part #.

Phenolic (R Roller Bearing)

PHN	4	2	800	5 ⁵ / ₈	3 ³ / ₈	—	ES4X2PHN
	5	2	1000	6 ¹ / ₂	4	—	ES5X2PHN
	6	2	1200	7 ¹ / ₂	4 ³ / ₄	—	ES6X2PHN
	8	2	1250	9 ¹ / ₂	6 ¹ / ₄	—	ES8X2PHN

To change the standard roller bearing to an optional bearing, add **B** (Precision Ball) or **D** (Delrin) to the end of the part #.

+ Swivel models shown in chart, for rigid models change 1st two digits "ES" to "ER".

Wheel Diameter (Inches)	Tread Width (Inches)	Capacity (Lbs) (Based on manual operation)	Overall Height (Inches)	Swivel Lead (Inches)	Approx. Wt. (Lbs)	Caster Number+

Thermo-Rubber (Flat) (R Roller Bearing)

TPR	4	2	300	5 ⁵ / ₈	3 ³ / ₈	—	ES4X2TPR
	5	2	350	6 ¹ / ₂	4	—	ES5X2TPR
	6	2	500	7 ¹ / ₂	4 ³ / ₄	—	ES6X2TPR
	8	2	600	9 ¹ / ₂	6 ¹ / ₄	—	ES8X2TPR

To change the standard roller bearing to an optional bearing, add **B** (Precision Ball) or **D** (Delrin) to the end of the part #.

Polyurethane HD (R Roller Bearing)

POD	4	2	500	5 ⁵ / ₈	3 ³ / ₈	—	ES4X2POD
	5	2	600	6 ¹ / ₂	4	—	ES5X2POD
	6	2	600	7 ¹ / ₂	4 ³ / ₄	—	ES6X2POD
	8	2	900	9 ¹ / ₂	6 ¹ / ₄	—	ES8X2POD

To change the standard roller bearing to an optional bearing, add **B** (Precision Ball) or **D** (Delrin) to the end of the part #.

Thermo-Urethane (Red/Black) (R Roller Bearing)

TPU	4	2	500	5 ⁵ / ₈	3 ³ / ₈	—	ES4X2TPU
	5	2	600	6 ¹ / ₂	4	—	ES5X2TPU
	6	2	720	7 ¹ / ₂	4 ³ / ₄	—	ES6X2TPU
	8	2	800	9 ¹ / ₂	6 ¹ / ₄	—	ES8X2TPU

To change the standard roller bearing to an optional bearing, add **B** (Precision Ball) or **D** (Delrin) to the end of the part #.

Mold-on Poly (R Roller Bearing)

MOP	4	2	800	5 ⁵ / ₈	3 ³ / ₈	—	ES4X2MOP
	5	2	1100	6 ¹ / ₂	4	—	ES5X2MOP
	6	2	1200	7 ¹ / ₂	4 ³ / ₄	—	ES6X2MOP
	8	2	1250	9 ¹ / ₂	6 ¹ / ₄	—	ES8X2MOP

To change the standard roller bearing to an optional bearing, add **B** (Precision Ball) to the end of the part #.

Cast Iron (R Roller Bearing)

CIR	4	2	800	5 ⁵ / ₈	3 ³ / ₈	—	ES4X2CIR
	5	2	1000	6 ¹ / ₂	4	—	ES5X2CIR
	6	2	1200	7 ¹ / ₂	4 ³ / ₄	—	ES6X2CIR
	8	2	1250	9 ¹ / ₂	6 ¹ / ₄	—	ES8X2CIR

To change the standard roller bearing to an optional bearing, add **B** (Precision Ball) to the end of the part #.

BRAKE SWIVEL RADIUS CHART

Wheel Diameter	Swivel Radius				
	Wheel Face Brake	Tread Lock Brake	Short Pedal Cam	Long Pedal Cam	Total Lock
4"	6-13/32"	3-5/8"	4-23/32"	N/A	5-7/16"
5"	7-1/32"	4"	5"	6"	5-13/16"
6"	7-21/32"	4-3/4"	5-1/2"	6-5/32"	6"
8"	9-1/16"	6-1/4"	6-1/4"	6-5/8"	6-3/8"

E-Line Components

Swivel and Rigid Rigs



Wheel Dia.	Tread Width	*Load Capacity (lbs)	Mount Height	Swivel Caster Part #	Rigid Caster Part #
4"	2"	1250	5-5/8"	RIG4X2ES	RIG4X2ER
5"	2"	1250	6-1/2"	RIG5X2ES	RIG5X2ER
6"	2"	1250	7-1/2"	RIG6X2ES	RIG6X2ER
8"	2"	1250	9-1/2"	RIG8X2ES	RIG8X2ER

Total Lock Rigs



Wheel Dia.	Tread Width	*Load Capacity (lbs)	Mount Height	Swivel Radius	Part #
4"	2"	900	5-5/8"	5-7/16"	RIG4X2EST
5"	2"	900	6-1/2"	5-13/16"	RIG5X2EST
6"	2"	900	7-1/2"	6"	RIG6X2EST
8"	2"	900	9-1/2"	6-3/8"	RIG8X2EST

*Some wheels have lower capacities. See pemcoasters.com/e/line for specifications.

Wheels

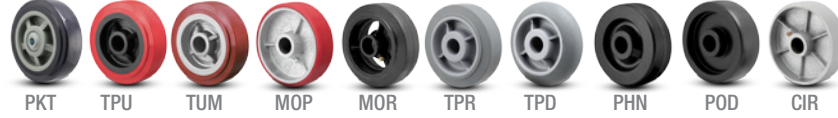

Wheel Dia.	Tread Width	Wheel Type	Load Capacity (lbs)	Standard Bore	Wheel Part # (Plain bore)
4"	2"	PolyKat™ Thermo-Urethane	600	1/2"	WH4X2PKTP8
		Thermo-Urethane (Red/Black)	500	1-3/16"	WH4X2TPU19
		Thermo-Urethane (Maroon/Grey)	500	1-3/16"	WH4X2TUM19
		Mold-on Poly	800	1-3/16"	WH4X2MOP19
		Mold-on Rubber	400	1-3/16"	WH4X2MOR19
		Thermo-Rubber (Flat)	300	1-3/16"	WH4X2TPR19
		Thermo-Rubber (Donut)	300	1-3/16"	WH4X2TPD19
		Phenolic	800	1-3/16"	WH4X2PHN19
		Polypropylene HD	500	1-3/16"	WH4X2POD19
5"	2"	Cast Iron	800	1-3/16"	WH4X2CIR19
		PolyKat™ Thermo-Urethane	800	1/2"	WH5X2PKTP8
		Thermo-Urethane (Red/Black)	600	1-3/16"	WH5X2TPU19
		Thermo-Urethane (Maroon/Grey)	600	1-3/16"	WH5X2TUM19
		Mold-on Poly	1100	1-3/16"	WH5X2MOP19
		Mold-on Rubber	400	1-3/16"	WH5X2MOR19
		Thermo-Rubber (Flat)	350	1-3/16"	WH5X2TPR19
		Thermo-Rubber (Donut)	350	1-3/16"	WH5X2TPD19
		Phenolic	1000	1-3/16"	WH5X2PHN19
6"	2"	Polypropylene HD	600	1-3/16"	WH5X2POD19
		Cast Iron	1000	1-3/16"	WH5X2CIR19
		PolyKat™ Thermo-Urethane	1000	1/2"	WH6X2PKTP8
		Thermo-Urethane (Red/Black)	720	1-3/16"	WH6X2TPU19
		Thermo-Urethane (Maroon/Grey)	720	1-3/16"	WH6X2TUM19
		Mold-on Poly	1200	1-3/16"	WH6X2MOP19
		Mold-on Rubber	550	1-3/16"	WH6X2MOR19
		Thermo-Rubber (Flat)	500	1-3/16"	WH6X2TPR19
		Thermo-Rubber (Donut)	500	1-3/16"	WH6X2TPD19
8"	2"	Phenolic	1200	1-3/16"	WH6X2PHN19
		Polypropylene HD	600	1-3/16"	WH6X2POD19
		Cast Iron	1200	1-3/16"	WH6X2CIR19
		PolyKat™ Thermo-Urethane	1200	1/2"	WH8X2PKTP8
		Mold-on Poly	1250	1-3/16"	WH8X2MOP19
		Thermo-Urethane (Red/Black)	800	1-3/16"	WH8X2TPU19
		Thermo-Urethane (Maroon/Grey)	800	1-3/16"	WH8X2TUM19
		Mold-on Rubber	600	1-3/16"	WH8X2MOR19
		Thermo-Rubber (Flat)	600	1-3/16"	WH8X2TPR19
8"	2"	Thermo-Rubber (Donut)	600	1-3/16"	WH8X2TPD19
		Phenolic	1250	1-3/16"	WH8X2PHN19
		Polypropylene HD	900	1-3/16"	WH8X2POD19
		Cast Iron	1250	1-3/16"	WH8X2CIR19

Brakes

All brake kits include axle, nut and necessary hardware to install on swivel or rigid rigs.

Tread Lock Brake (TBK)



TBK4X2E	4" models
TBK5X2E	5" models
TBK6X2E	6" models
TBK8X2E	8" models

Wheel Face Brake (WFB)



WFB4X2E	4" models
WFB5X2E	5" models
WFB6X2E	6" models
WFB8X2E	8" models

Not available on 4" and 5" rigid models.

Long Pedal Cam Brake 7" (CAML)

Only works with roller bearing models. Fits 5", 6" & 8" E-Line models.



CAMXX2L	Comes with custom spanner bushing (roller bearing required)
---------	---

Short Pedal Cam Brake 5" (CAMS)

Only works with roller bearing models. Fits all caster sizes.



CAMXX2S	Comes with custom spanner bushing (roller bearing required)
---------	---

Hardware (All hardware parts sold per piece, not sets)



Axle (Zerk)
1/2-13x3.75
AXLEZRKEX2

Nut
1/2-13
AXLENUTEX2

Spanner bushing
1/2 X 3/4 X 2-7/16
SPANNEREX2



Retaining Washer (Plastic)
WHLCAPPLEX2

Retaining Washer (Steel)
WHLCAPSTEX2

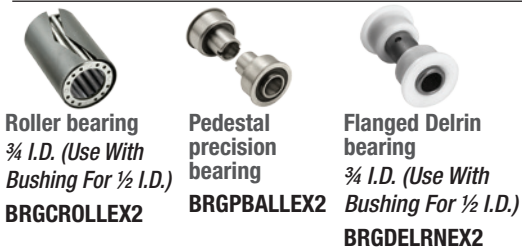

Roller bearing
3/4 I.D. (Use With Bushing For 1/2 I.D.)
BRGCROLLEX2

Pedestal precision bearing
BRGPBALLEX2

Flanged Delrin bearing
3/4 I.D. (Use With Bushing For 1/2 I.D.)
BRGDELRNEX2

Raceway Seals

Upper and Lower seals available on swivel caster models (Sold as set). Seals are not available for total lock models.



RCWYSEALEX2

4 Position Swivel Lock

Lock and unlock swivel for easy tracking down hallways



SWWLOCKX2

Floor Locks Designed to hold your portable equipment in a desired location.



Wheel Dia.	Caster Mtg. Ht.	Retracted Clearance	Approximate Weight (lbs)	Floor Lock #
4"	5-5/8"	3/4"	3-1/4	FL-4E
5"	6-1/2"	3/4"	3-1/2	FL-5E
6"	7-1/2"	3/4"	3-3/4"	FL-6E
8"	9-1/2"	3/4"	4"	FL-8E

Double Pedal Floor Locks Adaptable to all types of portable equipment, the double pedal floor lock allows for easier floor lock engagement.



Wheel Dia.	Caster Mtg. Ht.	Retracted Clearance	Approximate Weight (lbs)	Floor Lock #
4"	5-5/8"	1"	3-7/8	FLOCKE40
5"	6-1/2"	1"	4	FLOCKE50
6"	7-1/2"	1-3/8"	4-1/4	FLOCKE60
8"	9-1/2"	1-1/4"	4-3/4	FLOCKE80

02 14

Gate Casters CAPACITY TO 210



These casters are designed to make gate opening and closing easy. The casters feature gate mounts and spring loaded shock absorption.



Premium Quality



Environmentally Friendly

FEATURES

- Gate mount integrated in caster
- Spring loaded design provides shock absorption

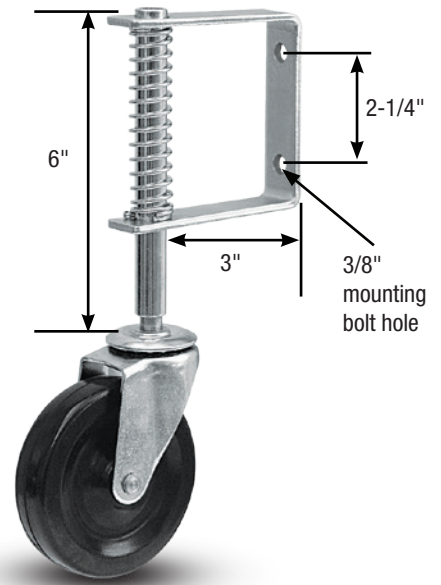

Wheel Diameter (Inches)	Tread Width/Type (Inches)	Capacity (Lbs) (Rates for manual operation)	Overall Height (Inches)	Swivel Lead (Inches)	Approx. Wt. (Lbs)	Caster Number
4	1	125	10-1/2	3.2		02RN04041S007

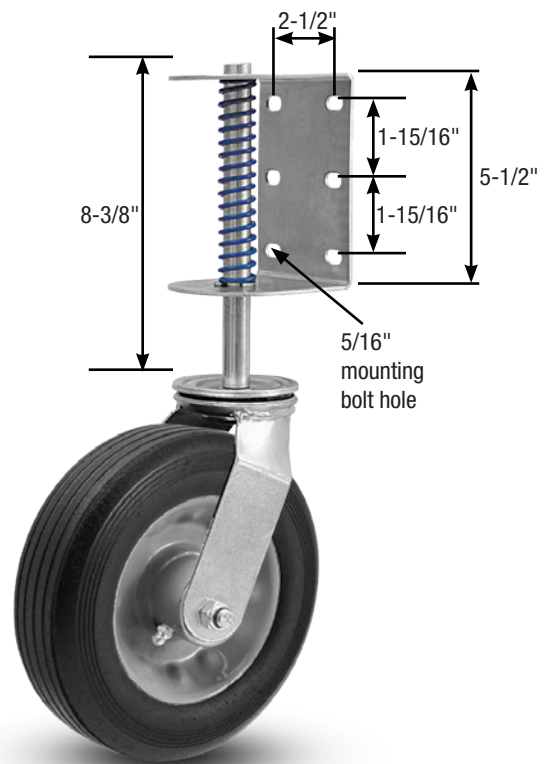

Wheel Diameter (Inches)	Tread Width/Type (Inches)	Capacity (Lbs) (Rates for manual operation)	Overall Height (Inches)	Swivel Lead (Inches)	Approx. Wt. (Lbs)	Caster Number
8	2-1/2	210	18-1/2	6.5		14SN08427S001